

**For Residential and Commercial Applications**

Job Name		Engineer / Architect	
Job Location		Wholesaler	
Submittal Date		Contractor	

## SR10/ SR12/ SR32 & SSR10/ SSR12/ SSR30 Multi-Turn Straight Stop w/ Loose Key – Female Iron Pipe x Compression

**Use:** For use in potable water distribution systems. Not intended for recirculating water systems that produce continuous use temperatures above 115° F. For those applications, use BrassCraft KT series ball stops

**Design Features:**

- **Machined one-piece brass body** provides strength, durability and long-lasting performance
- **Large loose key handle** provides a secure grip for trouble-free on/off operation
- **Removable loose key handle** helps protect against accidental stop operation during rough-ins and general use
- **Compliant Stops** available for California and Vermont “low-lead” requirements.

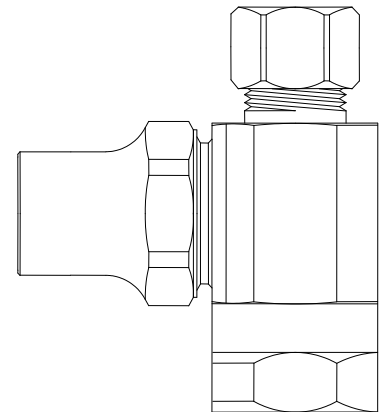

**Operating Specifications:**

**Temperature:** 40°- 140° F  
**Pressure:** 125 psi maximum

**Standard**

MATERIAL SPECIFICATIONS	
<b>Valve Body</b>	C36000 brass
<b>Lockshield Stem</b>	C36000 brass
<b>Bib &amp; Packing Washers</b>	Nitrile or EPDM rubber
<b>Packing Nut</b>	C36000 brass
<b>Loose Key</b>	Zinc die cast
<b>Compression Sleeve</b>	C36000 brass
<b>Compression Nut</b>	C36000 brass

**Compliant**

MATERIAL SPECIFICATIONS	
<b>Valve Body</b>	Compliant brass
<b>Lockshield Stem</b>	Compliant brass
<b>Bib &amp; Packing Washers</b>	Nitrile or EPDM rubber
<b>Packing Nut</b>	Compliant brass
<b>Loose Key</b>	Zinc die cast
<b>Compression Sleeve</b>	C36000 brass
<b>Compression Nut</b>	C36000 brass

**Standard Part Listing:**

- SR10 C      3/8" F.I.P. x 3/8" OD Compression with loose key handle, chrome plated
- SR10 R      3/8" F.I.P. x 3/8" OD Compression with loose key handle, rough brass
- SR12 C      1/2" F.I.P. x 3/8" OD Compression with loose key handle, chrome plated
- SR12 R      1/2" F.I.P. x 3/8" OD Compression with loose key handle, rough brass
- SR32 C      1/2" F.I.P. x 1/2" OD Compression with loose key handle, chrome plated
- SSR10 C     3/8" F.I.P. x 3/8" OD Compression with screwdriver slot, chrome plated
- SSR30 C     3/8" F.I.P. x 1/2" OD Compression with screwdriver slot, chrome plated
- SSR12 C     1/2" F.I.P. x 3/8" OD Compression with screwdriver slot, chrome plated

*This specification and all information contained herein is the confidential and exclusive property of BrassCraft Manufacturing, and shall not be disclosed to others without the written consent of BrassCraft. This specification must be returned to BrassCraft if requested.*



# SR10/ SR12/ SR32 & SSR10/ SSR12/ SSR30 Multi-Turn Straight Stop w/ Loose Key – Female Iron Pipe x Compression

**Compliant Part Listing:**

- SR12X C      1/2" F.I.P. x 3/8" OD Compression with loose key handle, chrome plated

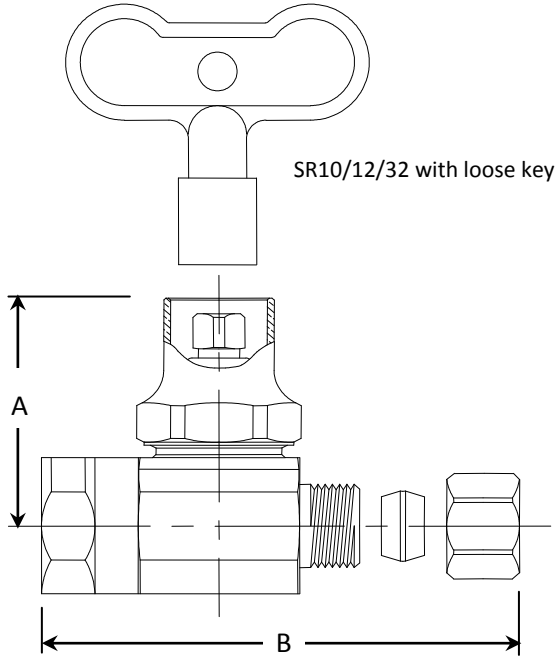

<b>PART DIMENSIONS (Inches)</b>		
<b>Model</b>	<b>DIM. A</b>	<b>DIM. B</b>
SR10	1.61	2.00
SR12	1.52	2.09
SR32	1.52	2.16
SSR10	1.61	2.00
SSR30	1.52	2.16
SSR12	1.52	2.09

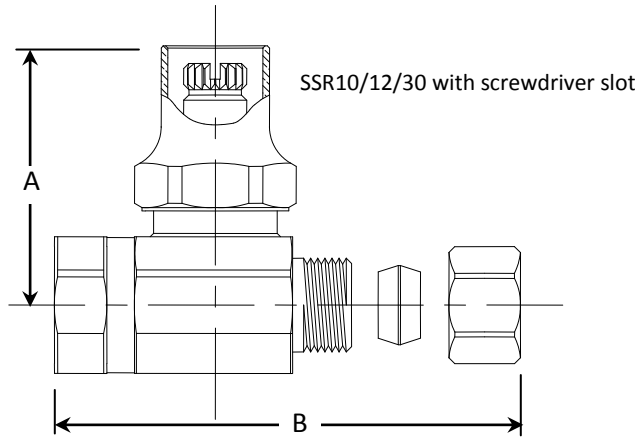

**Listings & Certifications:**

- IAPMO listed to ASME A112.18.1-05 / CSA B125.1-05 (File # 0645)
- CSA listed to ASME A112.18.1-05 / CSA B125.1-05 (File # 204593)
- Compliant product CSA approved to California Health and Safety Code 116875 and Vermont Bill S.152 (Project # 2174785)



*This specification and all information contained herein is the confidential and exclusive property of BrassCraft Manufacturing, and shall not be disclosed to others without the written consent of BrassCraft. This specification must be returned to BrassCraft if requested.*

**BrassCraft®**